



Single door 350KG  
Electromagnetic lock

EL-800D, EL-800S, EL-800SD, EL-800SZ, EL-800ST

Specifications

EL-800	Without indicator lights	
EL-800S	With LED (Red only)	
EL-800SD	LED, door sensor	 
EL-800ST	LED, door sensor, Time delay	  
EL-800SZ	LED, door sensor, Buzzer	  
Lock size	285Lx55Wx27.5H(mm)	
Armature Plate	190Lx45Wx11H(mm)	
Holding Force	350kg (800Lbs)	
Voltage	DC12V or DC24V (adjustable)	
Current Draw	12V/500mA 24V/250mA	
Signal Output	Dry Contact, Max Rating of Contact Current 3A	
Surface Temp	≤20°C	
Operating Temp	-10°C ~ 55°C (14°F~131°F)	
Suitable Humidity	0~90%(non-condensing)	
Finishes for Shell	Anodized aluminum surface texture processing	
Finishes for Magnetic	Zinc	
Finishes for Armature	Zinc	
Weight	2.5kg	
Standard Packing	8pcs	

# Dimensions

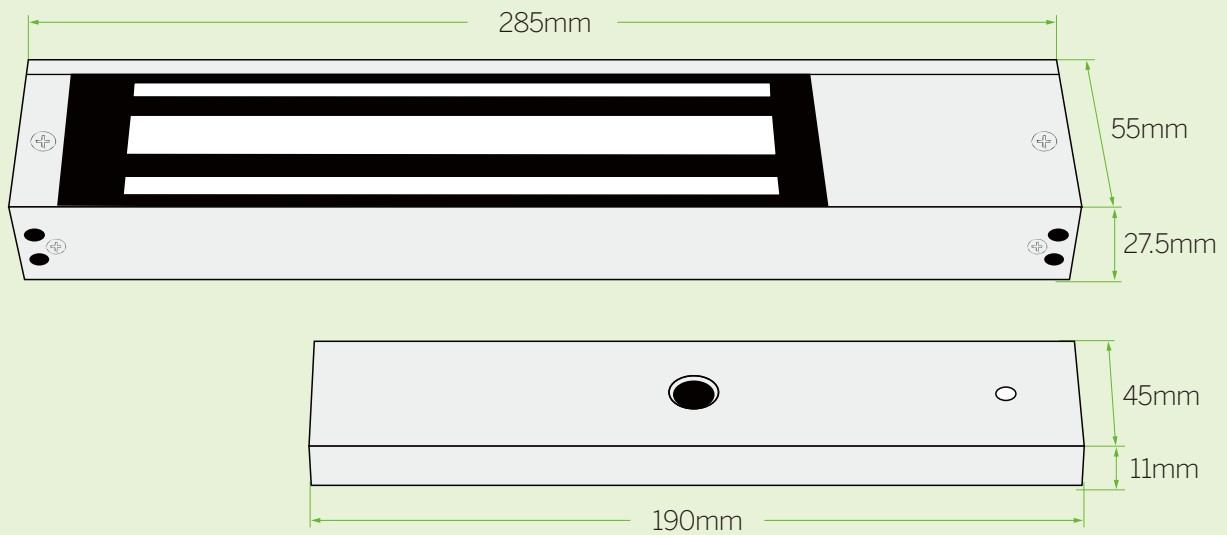

# Wiring diagram

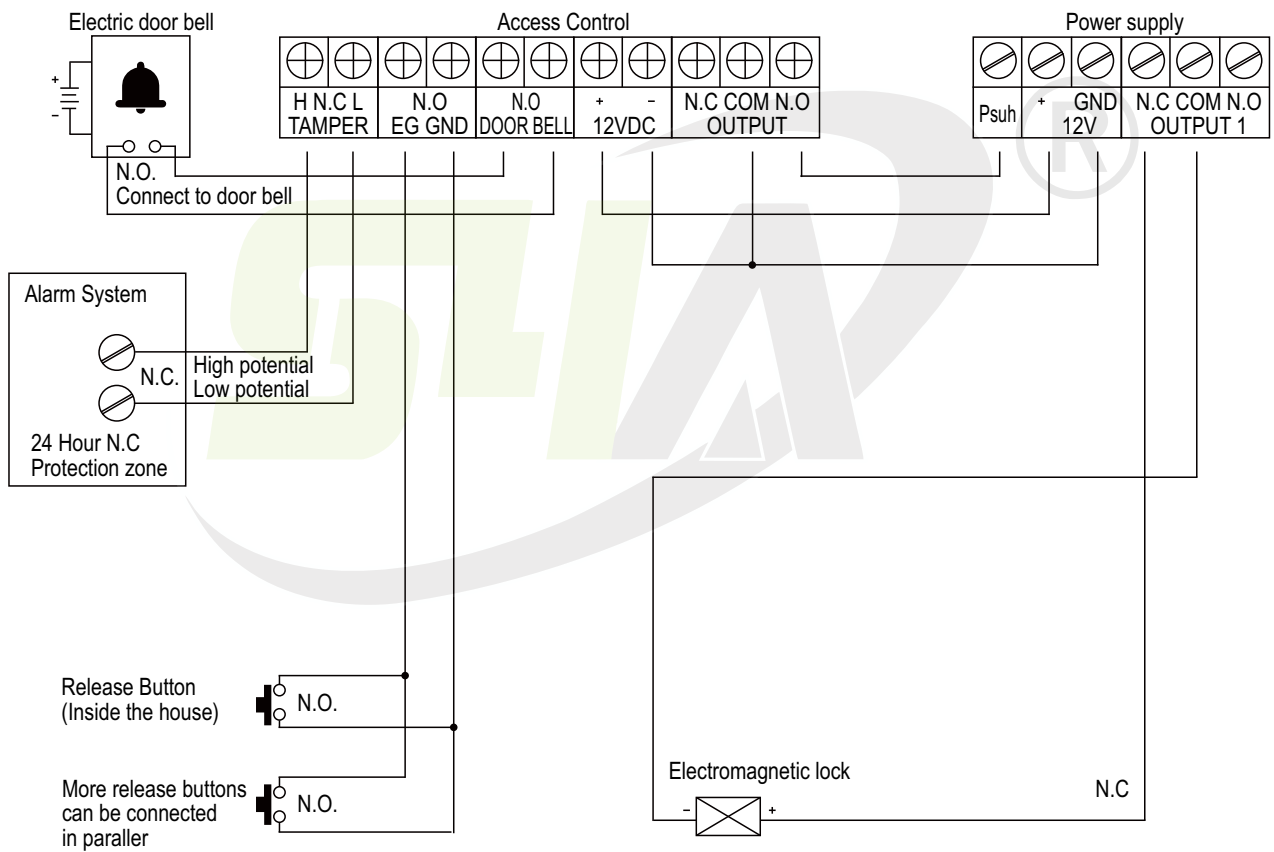

S4A Industrial Co., Limited

Address: The 2nd floor, Jinmin'an Industrial Zone, #529, Bulong Rd.  
Bantian St. Longgang Dist. Shenzhen, PRC.. CN 518131



Tel: +86 755 29450011

[www.s4a-access.com](http://www.s4a-access.com) / Email: [sales@s4a-access.com](mailto:sales@s4a-access.com)  
Mob/Whatsapp/Wechat/Viber: +86 134 1050 0721